

ALUMINUM ELECTROLYTIC CAPACITORS



NU Screw Terminal Type, 105°C
High Voltage, Smaller Sized.
series



NEW

- Suited for use in industrial power supplies for inverter circuitry, etc.
- Rated voltage range up to DC525V.
- Load life of 5000 hours application of ripple current at 105°C.
- High voltage / Smaller sized than NT series.
- Coped with loading of high speed charge-discharge.
- Suited for high frequency regenerative voltage for AC servomotor, general inverter.
- Compliant to the RoHS directive (2002/95/EC).

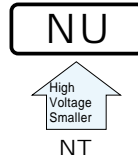

Specifications

Item	Performance Characteristics		
Category Temperature Range	- 40 to +105°C		
Rated Voltage Range	500 · 525V		
Rated Capacitance Range	680 to 8200μF		
Capacitance Tolerance	±20% (120Hz, 20°C)		
Leakage Current	After 5 minutes' application of rated voltage, leakage current is not more than $3\sqrt{CV}$ (μA) or 5 mA, whichever is smaller. (at 20°C) [C: Rated Capacitance(μF), V: Voltage (V)]		
Tangent of loss angle (tan δ)	0.2MAX. (120Hz at 20°C)		
Stability at Low Temperature	Rated voltage(V)	500 · 525	
	Impedance ratio ZT/Z20(MAX.)	Z - 40°C / Z+20°C 8	
Measurement frequency : 120Hz			
Insulation Resistance	The insulation resistance shall be more than 100MΩ at DC 500V application between terminal and bracket.		
Voltage proof	There is no abnormality during AC 2500V 1 minute's application between terminal and bracket.		
Endurance	The specifications listed at right shall be met when the capacitors are restored to 20°C after D.C. bias plus rated ripple current is applied for 5000 hours at 105°C, the peak voltage shall not exceed the rated voltage.	Capacitance change	Within ±20% of the initial capacitance value
		tan δ	200% or less than the initial specified value
		Leakage current	Less than or equal to the initial specified value
Shelf Life	After storing the capacitors under no load at 105°C for 1000 hours and then performing voltage treatment based on JIS C 5101-4 clause 4.1 at 20°C, they shall meet the requirements listed at right.	Capacitance change	Within ±20% of the initial capacitance value
		tan δ	200% or less than the initial specified value
		Leakage current	Less than or equal to the initial specified value
Endurance of charge - discharge behavior	After an application of charge-discharge voltage for 50million times (charge-discharge voltage difference(ΔV) = rated voltage × 0.3, cycle 3Hz) capacitors shall meet the characteristics requirement listed at right.	Capacitance change	Within ±20% of the initial capacitance value
		tan δ	200% or less than the initial specified value
		Leakage current	Less than or equal to the initial specified value
Marking	Printed with white color letter on black sleeve		

Drawing

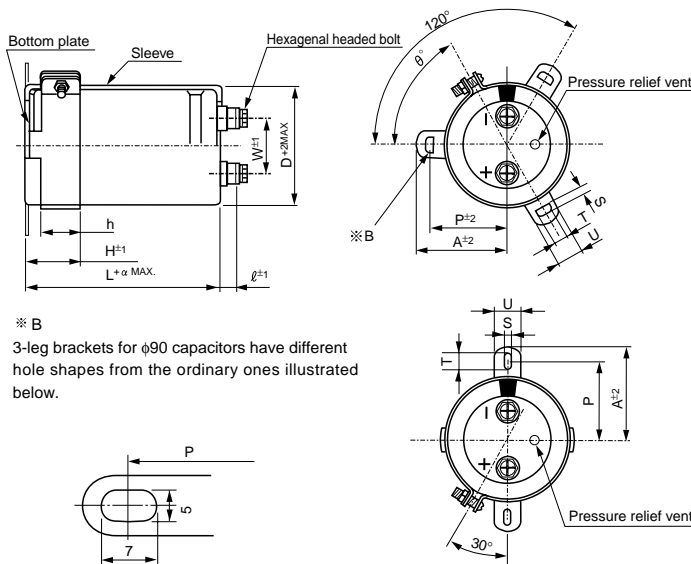

※ B
3-leg brackets for φ90 capacitors have different hole shapes from the ordinary ones illustrated below.

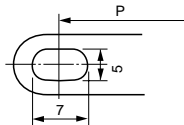

Note) The brackets will be supplied in the separate box.

● Dimension of terminal pitch (W) and length (ℓ) and Nominal dia. of bolt (mm)

φD	W	ℓ	α	Nominal dia. of bolt
51	22.0	6	3	M5
63.5	28.6	6	3	M5
76.2	31.8	6	3	M5
90	31.8	6	3	M5

About product of stud bolt
 • Nylon nut and nylon washer attachment become the standard specifications. (cf. P.282)
 • It is not attached to the bracket.
 • Field 13 and 14 become blank in Type number system.

Type numbering system (Example : 500V 4700μF)

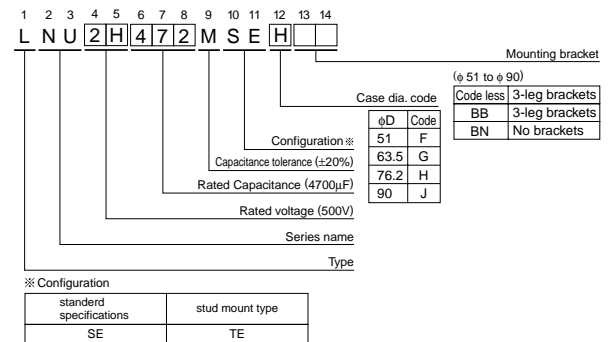

Please refer to page 282 for schematic of dimensions.
 ※ Please contact to us if PVC less products are required.

Dimensions of mounting bracket (mm)

Symbol	Leg shape	3-Leg			2-Leg				
		51	63.5	76.2	90	51	63.5	76.2	90
P		32.5	38.1	44.5	50.8	33.2	40.5	46.5	53
A		38.5	43	49.2	58.5	40	46.5	53	59
T		7.5	8.0	7.0	8.0	6.0	7.0	6.0	6.0
S		5.0	5.0	5.0	5.0	4.5	4.5	4.5	4.5
U		12	14	14	18	14	14	14	14
θ°		60	60	60	60	30	30	30	30
H		20	25	30	35	25	35	35	35
h		15	20	24	25	15	20	20	20

● Dimension table in next page.

CAT.8100B

NU series

■ Dimensions

500V (2H)					
Cap. (μF)	Size φD × L(mm)	Rated ripple (Arms)	tan δ	Leakage Current (mA)	Code
680	51 × 75	4.0	0.20	1.75	LNU2H681MSEF
1000	51 × 90	5.0	0.20	2.12	LNU2H102MSEF
1200	51 × 115	5.7	0.20	2.32	LNU2H122MSEF
	63.5 × 80	5.7	0.20	2.32	LNU2H122MSEG
1500	51 × 135	6.6	0.20	2.60	LNU2H152MSEF
	63.5 × 90	6.6	0.20	2.60	LNU2H152MSEG
1800	63.5 × 100	7.4	0.20	2.85	LNU2H182MSEG
	76.2 × 70	7.4	0.20	2.85	LNU2H182MSEH
2200	63.5 × 120	8.5	0.20	3.15	LNU2H222MSEG
	76.2 × 95	8.5	0.20	3.15	LNU2H222MSEH
2700	63.5 × 135	9.6	0.20	3.49	LNU2H272MSEG
	76.2 × 105	9.6	0.20	3.49	LNU2H272MSEH
3300	63.5 × 165	10.9	0.20	3.85	LNU2H332MSEG
	76.2 × 130	10.9	0.20	3.85	LNU2H332MSEH
3900	76.2 × 145	12.4	0.20	4.19	LNU2H392MSEH
	90 × 105	12.4	0.20	4.19	LNU2H392MSEJ
4700	76.2 × 165	13.9	0.20	4.60	LNU2H472MSEH
	90 × 125	13.9	0.20	4.60	LNU2H472MSEJ
5600	90 × 145	15.8	0.20	5.00	LNU2H562MSEJ
6800	90 × 165	18.5	0.20	5.00	LNU2H682MSEJ
8200	90 × 205	20.2	0.20	5.00	LNU2H822MSEJ

525V (N7)					
Cap. (μF)	Size φD × L(mm)	Rated ripple (Arms)	tan δ	Leakage Current (mA)	Code
680	51 × 85	4.4	0.20	1.75	LNUN7681MSEF
1000	51 × 95	5.4	0.20	2.12	LNUN7102MSEF
1500	63.5 × 95	7.2	0.20	2.60	LNUN7152MSEG
1800	63.5 × 105	8.0	0.20	2.85	LNUN7182MSEG
2200	63.5 × 135	9.2	0.20	3.15	LNUN7222MSEG
	76.2 × 100	9.2	0.20	3.15	LNUN7222MSEH
2700	76.2 × 115	10.6	0.20	3.49	LNUN7272MSEH
3300	76.2 × 140	12.1	0.20	3.85	LNUN7332MSEH
4700	76.2 × 185	15.2	0.20	4.60	LNUN7472MSEH
	90 × 135	15.2	0.20	4.60	LNUN7472MSEJ
5600	90 × 155	17.5	0.20	5.00	LNUN7562MSEJ

Rated ripple current (Arms) at 105°C 120Hz

● Frequency coefficient of rated ripple current

Frequency (Hz)	50	60	120	360	1k	10k or more
Coefficient	0.80	0.82	1.00	1.20	1.30	1.40